

PS Series

Hydraulic Power Packs

Our PS Series Power Packs not only for vibratory hammers but also for many different industrial applications like vessels and dam projects. Our engineering team always design our PS Series power packs according to the transport dimensions internationally recognised.

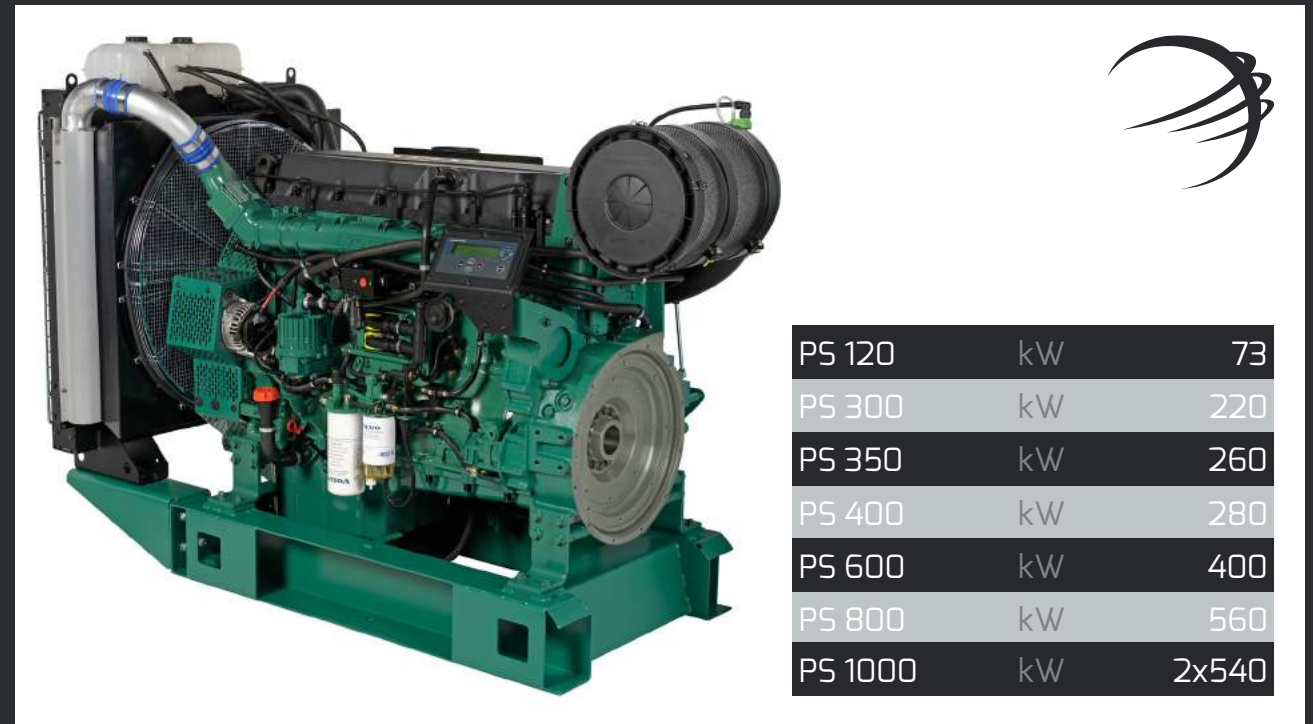

PS 120	kW	73
PS 300	kW	220
PS 350	kW	260
PS 400	kW	280
PS 600	kW	400
PS 800	kW	560
PS 1000	kW	2x540



We manufacture hydraulic PS series power packs. The advantage of our our hydraulic power packs is that we install open - circuit lines inside the cabin. The open - circuit line is always better to make quick repair and reducing the cost of repairs when compared with close - circuit systems.



The main cabin body is very strong to make transport many times in construction sites.

We apply special isolation walls inside the cabins to prevent hot or cold weather conditions bad effects.



The standard PS series Power Packs have cable-remote control systems as standard 15 mt. We offer also wireless remote control systems as optional. Each units have operator emergency stop buttons to help operator when needed.



We always use top-brand quality pumps and diesel engines in our power pack systems like Rexroth and Volvo Penta diesel engines. We have also options to install economic Ford diesel engines and Kawasaki pumps.

All of the PS series Power Packs has cooling systems both for hydraulic oil and gear box cooling. The user friendly control panel in all PS Series Power Packs helps operator to understand and check all system status clearly.



PS 120



Power Pack

PS120 is specially designed to operate small size vibratory hammers like ESF1-2-3-4 to drive vinyl PVC sheet piles or small posts. By means of this small size power pack, the need for excavator is eliminated.

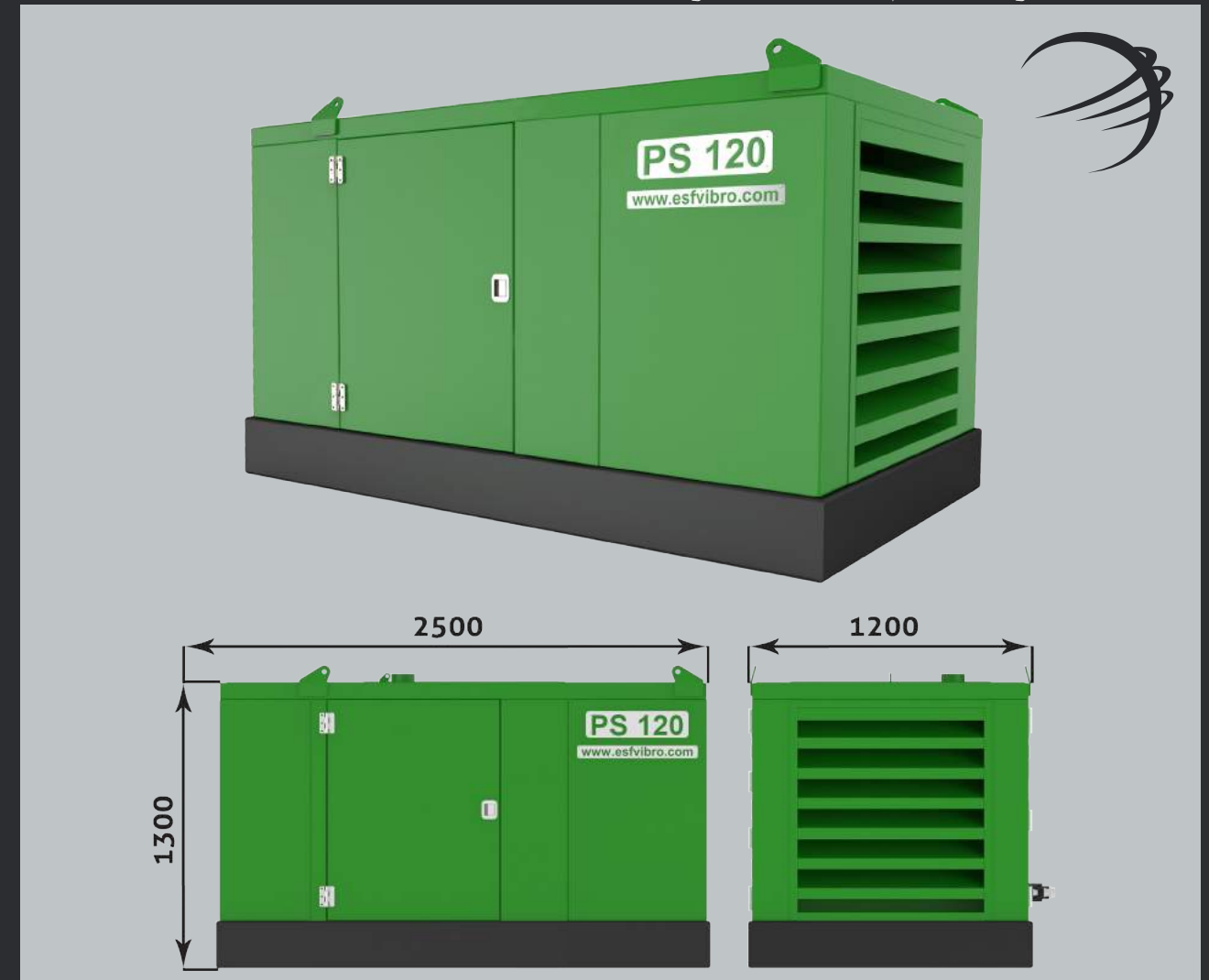

Power Pack (For Vibro Hammer)		ESF 1-2-3-4
Diesel Engine		Optional
Max. Working Pressure	bar	300
Max. Flow	l/min	120
Pump		Optional
Fueltank	lt	200
Hydraulic Tank	lt	300
Weight	kg	1400
Length	mm	2500
Width	mm	1200
Height	mm	1300

PS 300



Power Pack

PS300 Power Pack is designed and manufactured to operate crane hanging ESF 12-20-23 kgm vibratory hammers which are normal frequency.

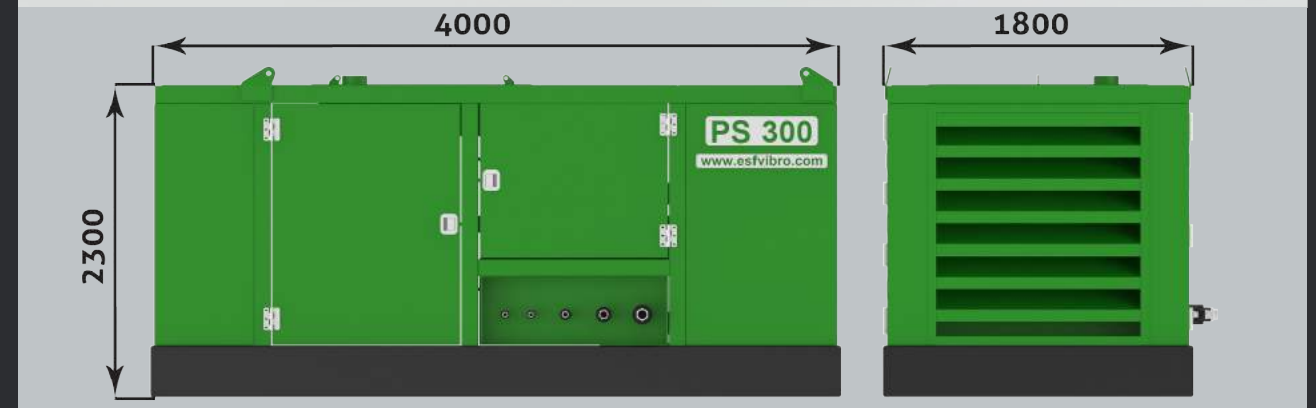

Power Pack (For Vibro Hammer)

ESF 12-20-23

Diesel Engine		Optional
Max. Working Pressure	bar	350
Max. Flow	l/min	300
Pump		Optional
Fueltank	lt	600
Hydraulic Tank	lt	800
Weight	kg	4200
Length	mm	4000
Width	mm	1800
Height	mm	2300



PS 350



Power Pack

PS350 is designed and manufactured for high-frequency ESF vibratory hammers.

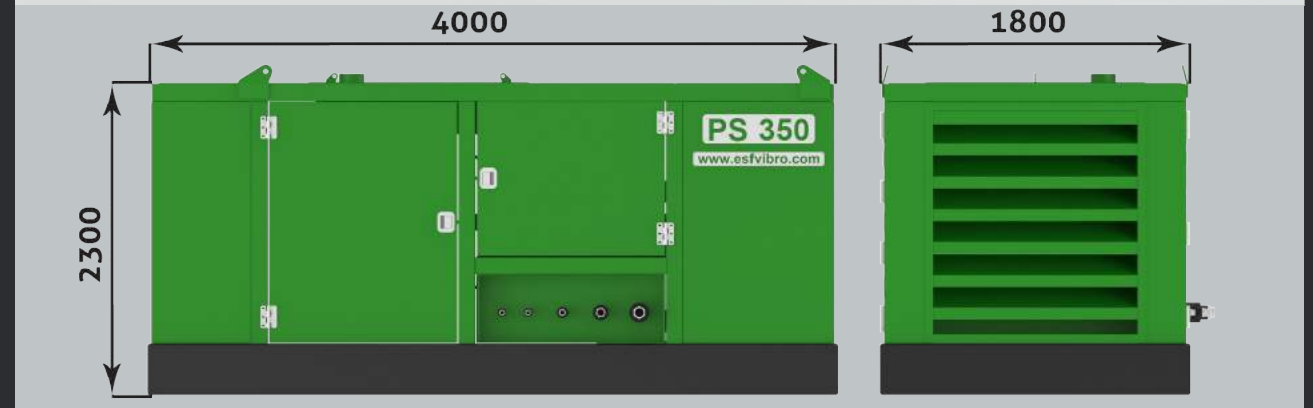

Power Pack (For Vibro Hammer)

ESF 14-20-23

Diesel Engine		Optional
Max. Working Pressure	bar	350
Max. Flow	l/min	350
Pump		Optional
Fueltank	lt	600
Hydraulic Tank	lt	800
Weight	kg	4200
Length	mm	4000
Width	mm	1800
Height	mm	2300



PS 400



Power Pack

PS 400 is designed and manufactured to operate ESF 30 size Normal Frequency Vibratory Hammer. This size power pack is optimum size.

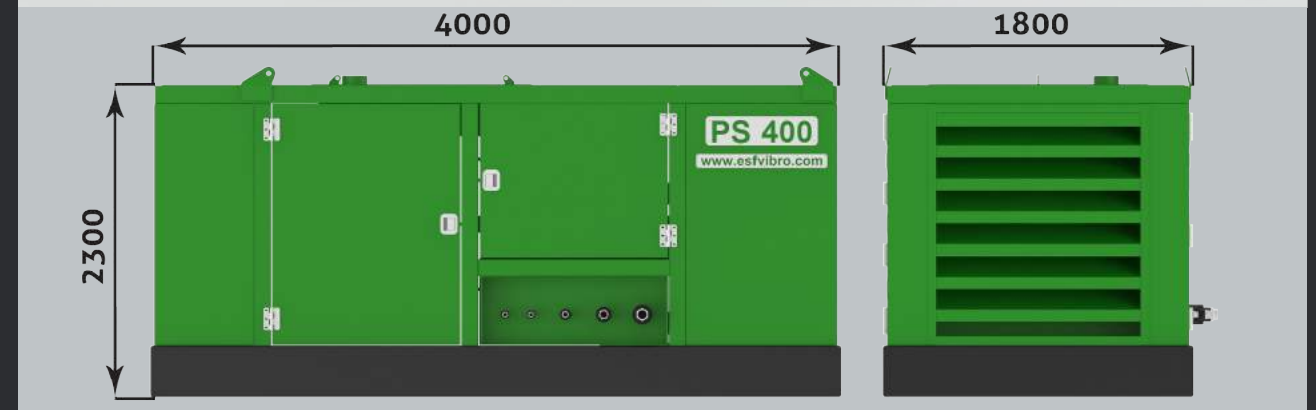

Power Pack (For Vibro Hammer)		ESF 30-33
Diesel Engine		Optional
Max. Working Pressure	bar	350
Max. Flow	l/min	400
Pump		Optional
Fueltank	lt	660
Hydraulic Tank	lt	950
Weight	kg	5600
Length	mm	4000
Width	mm	1800
Height	mm	2300



PS 600



Power Pack

PS 600 is designed and manufactured to operate ESF 55 size vibratory hammer. This power pack is capable to supply 600lt /min . oil flow @ 300 bar pressure.

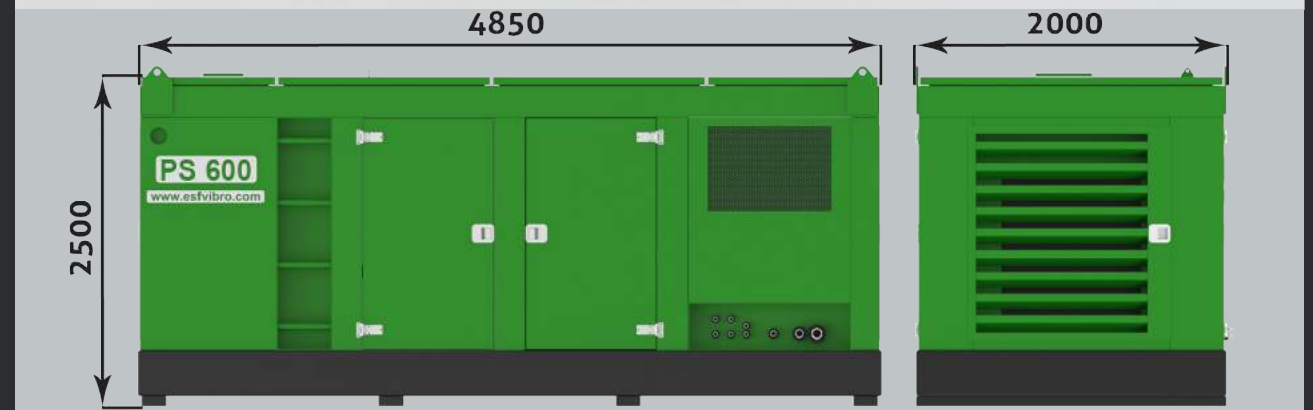

Power Pack (For Vibro Hammer)		ESF 55
Diesel Engine		Optional
Max. Working Pressure	bar	350
Max. Flow	l/min	600
Pump		Optional
Fueltank	lt	660
Hydraulic Tank	lt	1400
Weight	kg	7790
Length	mm	4850
Width	mm	2000
Height	mm	2500



PS 800



Power Pack

PS 800 is designed and manufactured to operate ESF 88 vibratory hammer. This power pack is capable to supply 800 lt/min.oil flow @ 350 bar pressure.

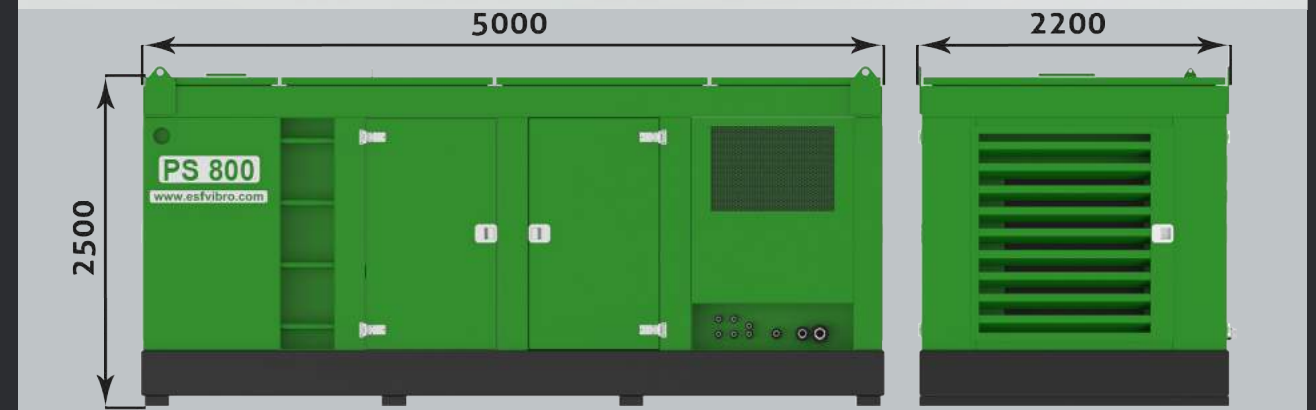

Power Pack (For Vibro Hammer)		ESF 88
Diesel Engine		Optional
Max. Working Pressure	bar	350
Max. Flow	l/min	800
Pump		Optional
Fueltank	lt	1200
Hydraulic Tank	lt	2450
Weight	kg	10400
Length	mm	5000
Width	mm	2200
Height	mm	2500

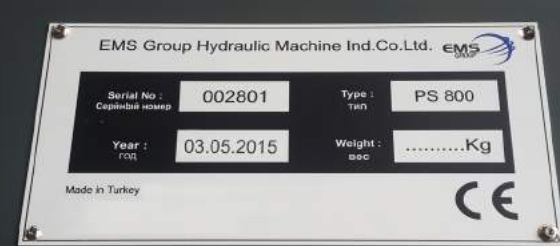

PS 1000



Power Pack

PS1000 is designed and manufactured to operate ESF110 vibratory hammer. This power pack is capable to supply 1000 lt/min.oil flow @ 350 bar pressure.

To operate ESF200 size Vibratory Hammer 2xPS1000 is used.

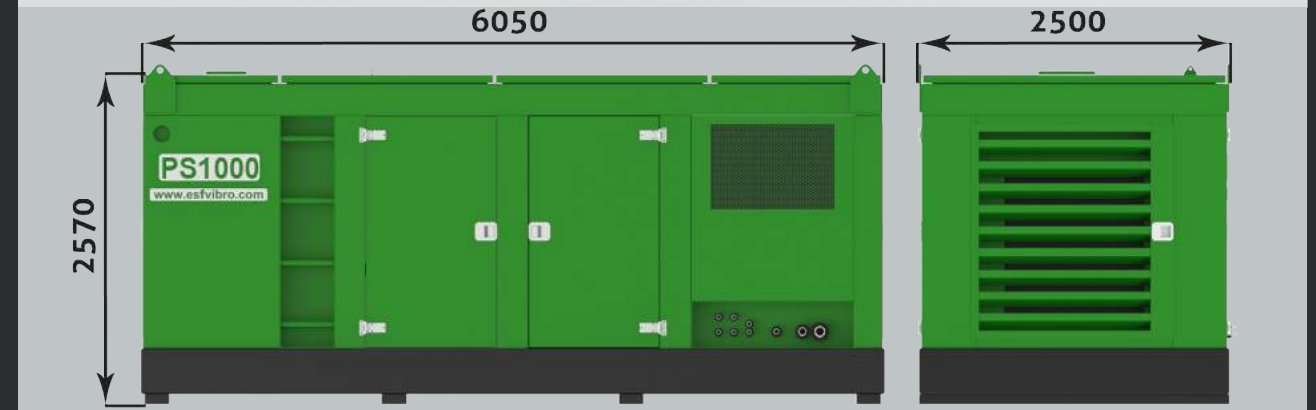

Power Pack (For Vibro Hammer)		ESF 110
Diesel Engine		Optional
Max. Working Pressure	bar	350
Max. Flow	l/min	1000
Pump		Optional
Fueltank	lt	1300
Hydraulic Tank	lt	2600
Weight	kg	1200
Length	mm	6050
Width	mm	2500
Height	mm	2570



CLAMPS



FCM & PCM Series Clamps

We manufacture the clamps out of solid steels not to let happen any crack during application. FCM and PCM series clamps are specially designed for ESF Series Vibratory Hammers on the other hand, we can also manufacture clamps for any other brand vibratory hammers.

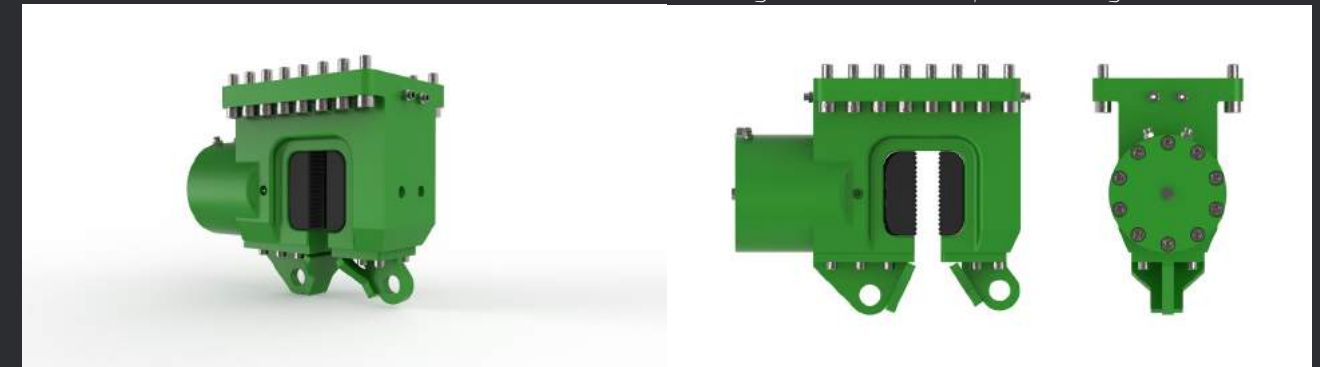

FCM 15	15 tons clamp	20 mm Mouth	Suitable for ESF 1B
FCM 30	30 tons clamp	28 mm Mouth	Suitable for ESF 2-3-4B
FCM 60	60 tons clamp	40 mm Mouth	Suitable for ESF 6B
FCM 75	75 tons clamp	40 mm Mouth	Suitable for ESF 7B
FCM 90	90 tons clamp	55 mm Mouth	Suitable for ESF 8-12-14B
FCM 100	100 tons clamp	45 mm Mouth	Suitable for ESF 20-23NF
FCM 180	180 tons clamp	70 mm Mouth	Suitable for ESF55C/NF

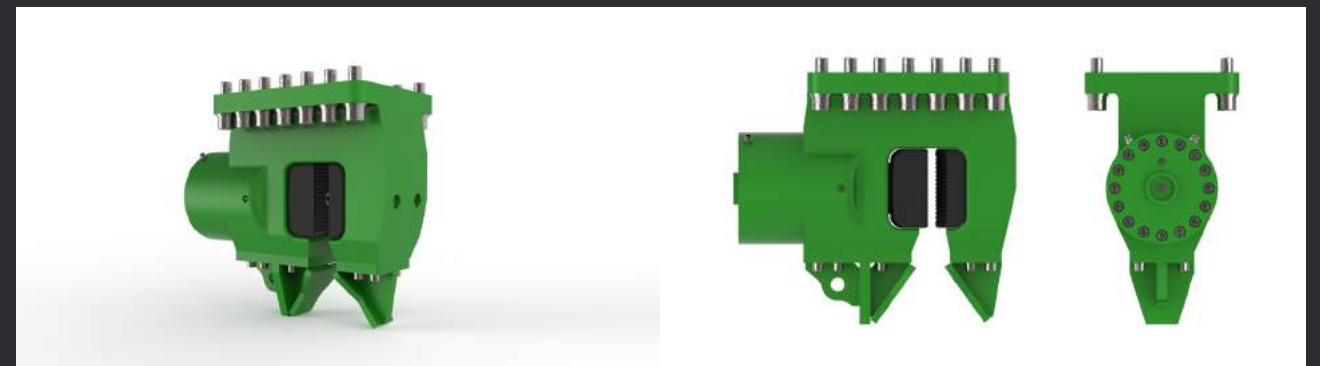

PCM 40	40 tons clamp	With Radius Clamp Shoes	Suitable for ESF 20-23NF
PCM 80	80 tons clamp	With Radius Clamp Shoes	Suitable for ESF 20-23NF
PCM 100	100 tons clamp	With Radius Clamp Shoes	Suitable for ESF 55C/NF

Tension Bar

From Ø 600 mm to 3000 mm
Suitable for ESF 20-23-55-88-110

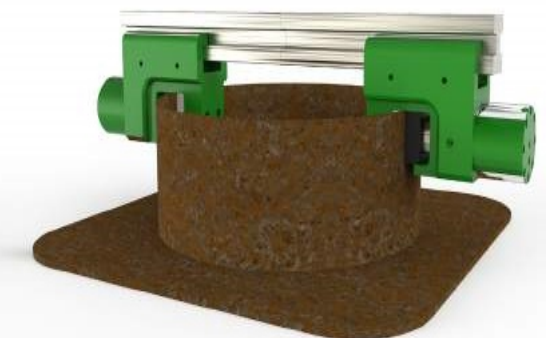



Walter Kim
WD International Inc.
Dealer in Ontario Canada
514- 893- 3189
wdkim@wdintlinc.com
www.wdintlinc.com